

ASUD Series

- Feature: Long life · Miniaturization (D size)
- Endurance 2000hrs at 125°C
- Rate voltage: 16-25 Vdc.



Specifications			
Item	Conditions	Characteristics	
Category Temperature Range		-40~ +125°C	
Rated Voltage Range		16 to 25V.DC,	
Capacitance Tolerance	at 20°C, 120Hz	±20 %	
Leakage Current	at 20°C after 2 minutes	I ≤ 0.3CV (16 V.DC to 25 V.DC) I : Leakage Current(μA), C : Rated Capacitance(μF), V : Rated Voltage(V)	
Surge Voltage	15°C to 35°C	Rated voltage × 1.15 (16 V.DC to 25 V.DC)	
Dissipation Factor (tanδ)	at 20°C · 120Hz	0.10 max.	
Endurance	125°C, rated voltage applied,2000 hrs	Appearance	No significant damage
		Capacitance Change	±20% of initial value
		Dissipation Factor	≤ 200% of the initial specified value
		Leakage Current	≤ 300% of the initial specified value
Damp Heat, Steady State	60°C, 90 to 95%RH, 500 hrs.	Appearance	No significant damage
		Capacitance Change	(16 V.DC to 25 V.DC) +60%, -20% of the initial value
		Dissipation Factor	≤ 200% of the initial specified value
		Leakage Current	(16 V.DC to 25 V.DC) ≤ 300% of the initial specified value
Surge Voltage	The capacitors shall be subjected to 1000 cycles each consisting of charge with the surge voltages, 125% rated voltage, at 15°C to 35°C for 30 seconds through a protective resistor(R=1KΩ)and discharge for 5min 30 seconds.	Appearance	No significant damage
		Capacitance Change	±10% of the initial value
		Dissipation Factor	within the initial specified value
		Leakage Current	within the initial specified value
Solderability	Pb-free solder Around 25% rosin melted ethanol or isopropylalcohol Temperature : 245 ± 5 °C Immersing time : 2 ± 0.5 s	More than 95% of outer terminal surface to be covered	
Resistance to Solvents	Solvent : isopropylalcohol Immersing time : 30 ± 5 s Room temperature	No significant damage and marking readable	
Shelf life	Test temperature:105±2°C Test time:500hrs.	Appearance	No significant damage
		Capacitance Change	±10% of the initial value
		Dissipation Factor	within the initial specified value
		Leakage Current	within the initial specified value

ASUD Series

Standard Ratings

WV (VDC)	Case size (mm)			Specifications				Ripple Current* ¹ (mA r.m.s) @100kHz	Part No.
	L	W	H	Cap (μF)@120Hz	tanδ Max. @120Hz	ESR Max.* ² (mΩ) @100kHz	Leakage Current Max. (μA)		
16	7.3	4.3	1.9	68	0.1	40	326.4	3000	ASUD160S680E40
	7.3	4.3	1.9	100	0.1	40	480	3000	ASUD160S101E40
	7.3	4.3	1.9	150	0.1	40	720	3000	*ASUD160S151E40
20	7.3	4.3	1.9	100	0.1	40	600	3000	ASUD200S101E40
	7.3	4.3	1.9	100	0.1	55	600	3000	ASUD200S101E55
25	7.3	4.3	1.9	33	0.1	40	247.5	3000	*ASUD250S330E40
	7.3	4.3	1.9	47	0.1	40	352.5	3000	*ASUD250S470E40
	7.3	4.3	1.9	68	0.1	70	510	3000	*ASUD250S680E70
	7.3	4.3	1.9	100	0.1	60	750	3000	*ASUD250S101E60
	7.3	4.3	2.8	150	0.1	50	750	3000	*ASUD250H151E50

*Engineering

*1:Ripple Current:(100kHz / +45°C)

*2:ESR Max (100kHz / +20°C)

Temperature Compensation Multipliers for Ripple Current				
	≤ 45°C	45°C < T ≤ 85°C	85°C < T ≤ 105°C	125°C < T
16 V.DC to 25 V.DC	1.0	0.8	0.5	0.25

PRODUCT IDENTIFICATION

<u>ASUD</u>	<u>160</u>	<u>S</u>	<u>680</u>	<u>E40</u>
Product	Rated Voltage	Case Height	Capacitance	ESR
	160: 16V	S:1.9mm H:2.8mm	680=68μF	E40: 40mΩ

DIMENSIONS AND MARKING

Case size	L	W	H	P	PA
D	7.3±0.2	4.3±0.2	1.9±0.1	1.3±0.2	≤ 0.3
			2.8±0.3		

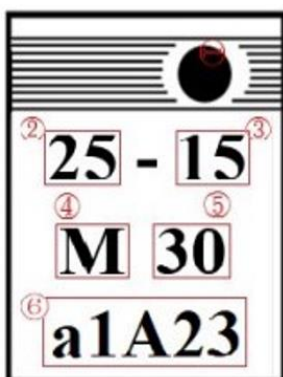
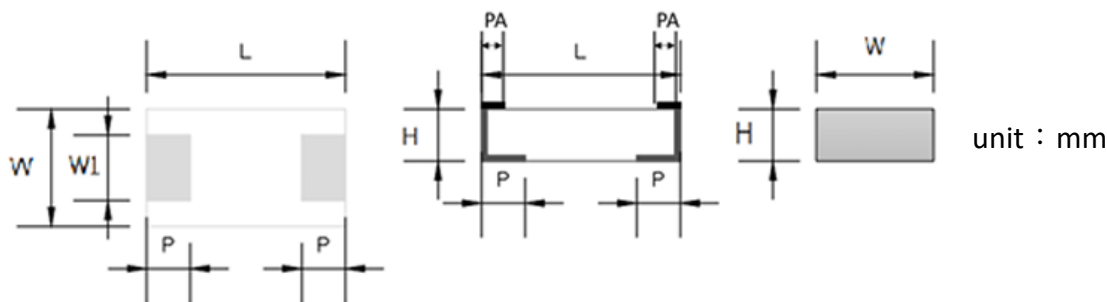

- ① : Polarity Bar (+)
- ② : Rated Voltage
- ③ : Rated Capacity
- ④ : Year (Q for 2025、R for 2026、S for 2027、T for 2028)
- ⑤ : Week
- ⑥ : Serial Code